

# APPROVED FLOW ACTIVATED SWITCH & PLC

## CONTROLLER

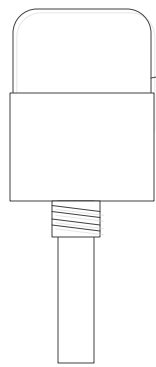

**FLOW SWITCH**

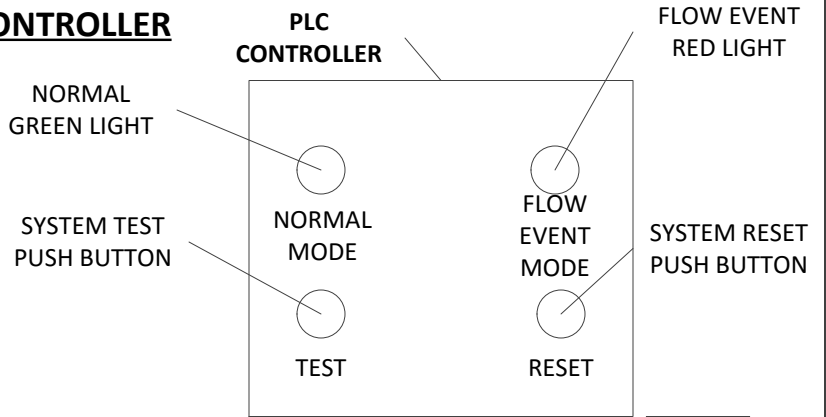

6' MAX.

GROUND

## SYSTEM LAYOUT

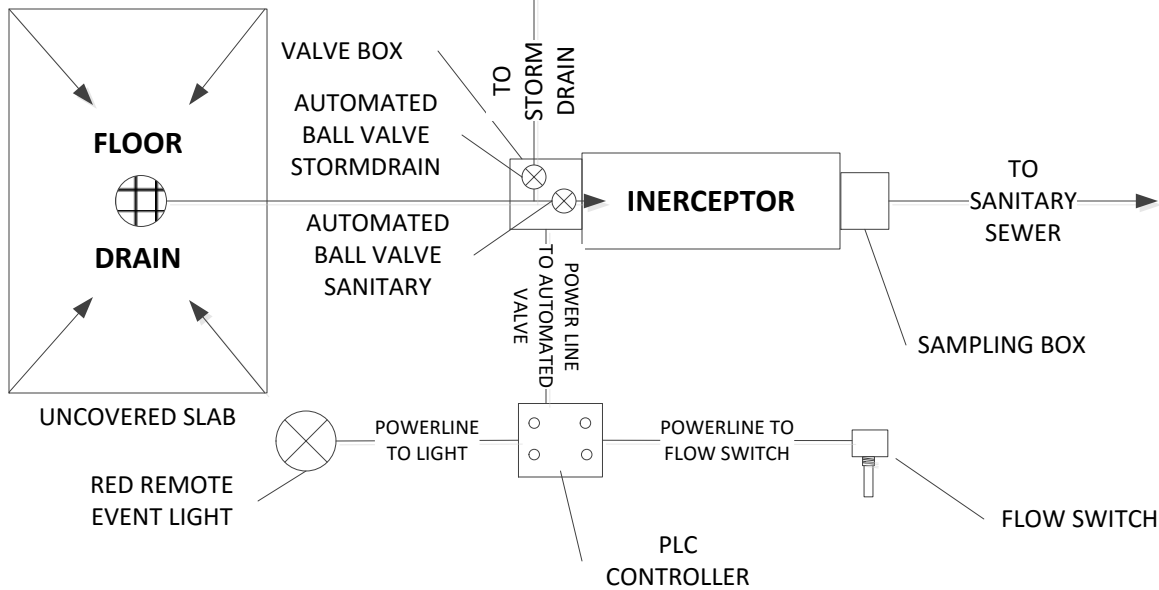

## SECTION A-A

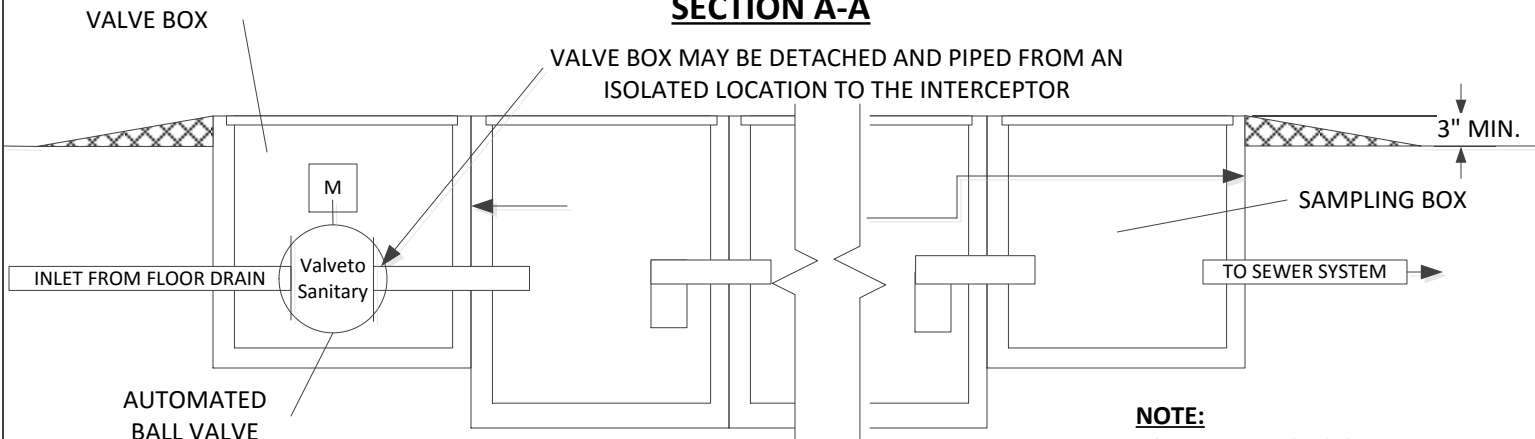

**NOTE:**  
FOR DIMENSIONS OF  
INTERCEPTOR AND SAMPLING  
BOX SEE STANDARD PLAN 2041.

[WWW.CIAGENT-STORMWATER.COM](http://WWW.CIAGENT-STORMWATER.COM)

REV 0	AUTOMATIC STORMWATER DIVERSION SYSTEM	9/15/2015	STANDARD PLAN (2) 2-WAY AUTOMATED VALVE SHEET 1 of 2
TITLE			
APPROVED			

## NOTES

1. *NORMAL CONDITION THE UNCOVERED SLAB WILL NOT HAVE ACCESS TO THE SANITARY. NORMAL CONDITION THE UNCOVERED SLAB WILL ALLOW RAIN WATER TO STORM DRAIN.*
2. *EVENT MODE THE FLOW SWITCH (ONCE ACTIVED WITH FLOW) WILL PROVIDE A SIGNAL TO THE PLC. IF MAINTAINED MORE THAN 15 SECONDS THE PLC OPENS THE AUTOMATED VALVE AND FULL ACCESS TO THE SANITARY SEWER. THE UNCOVERED SLAB WILL NOW DRAIN TO THE SANITARY. ONCE FLOW STOPS (AT LEAST 15 MIN) THE PLC WILL CLOSE THE AUTOMATED VALVE AND ACCESS TO THE SANITARY SEWER.*
3. *VALVE WILL BE FULL PORT DESIGN TO PREVENT DEBRIS FROM BACKING UP FLOW.*
4. *THE FLOW SWITCH MUST BE LOCATED NEAREST POSSIBLE TO THE OUTLET OF THE WASH WATER.*
5. *AUTOMATED VALVE WILL BE RATED FOR SUBMERSION.*
6. *VALVE WILL BE DESIGNED AND CONFIGURED AS A FULL PORT BALL VALVE WITH AN INLET FROM THE UNCOVERED SLAB AND OUTLET NORMALLY TO THE SANITARY .*
7. *THE VALVE WILL ALSO HAVE A PROVISION TO AUTOMATICALLY FULLY CLOSE AND THEN FULLY OPEN THE VALVE AT LEAST EVERY 7 DAYS SHOULD IT NOT OTHERWISE BE EXERCISED BY WASH EVENT OR OTHERWISE EXERCISING TO KEEP THE VALVE AND ACTUATOR IN GOOD RUNNING ORDER.*
8. *THE CONTROLLER WILL INDICATE BY CONTINUALLY BLINKING LIGHTS SHOULD THE AUTOMATED VALVE EVER BECOME DISABLED AND NOT REACH ITS INTENDED POSITION.*
9. *THE AUTOMATED VALVE MUST HAVE A MANUAL OVERRIDE INCASE OF LOSS OF POWER*
10. *PLC SHALL AUTOMATICALLY RESTART UPON RESTORATION OF ELECTRICITY AFTER A POWER OUTAGE.*

[WWW.ATTITUDESYSTEMS.COM](http://WWW.ATTITUDESYSTEMS.COM)

(714) 880-9992 Phone