

APPROVED RAIN ACTIVATED SWITCH & PLC CONTROLLER

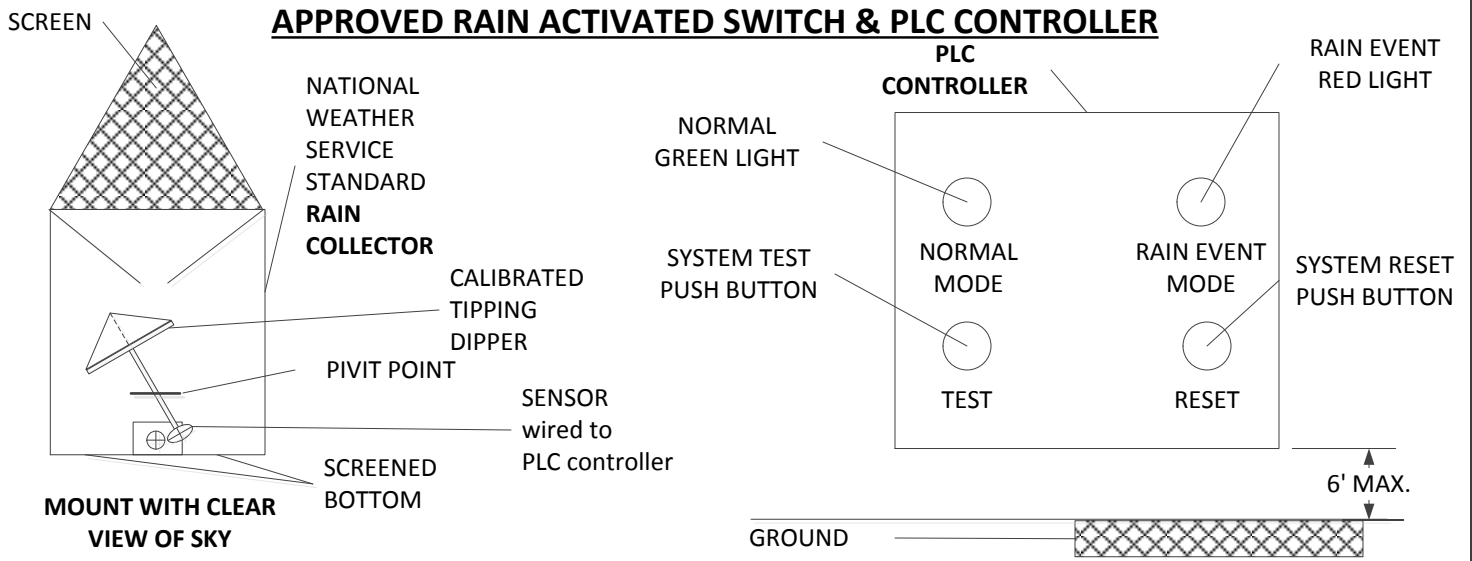

SYSTEM LAYOUT

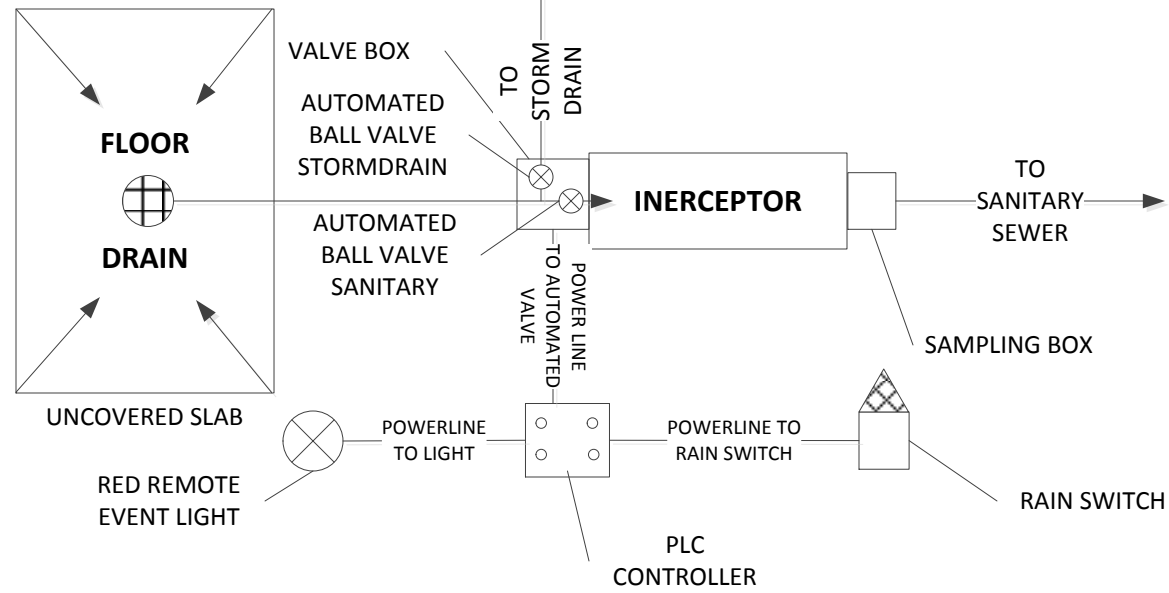

SECTION A-A

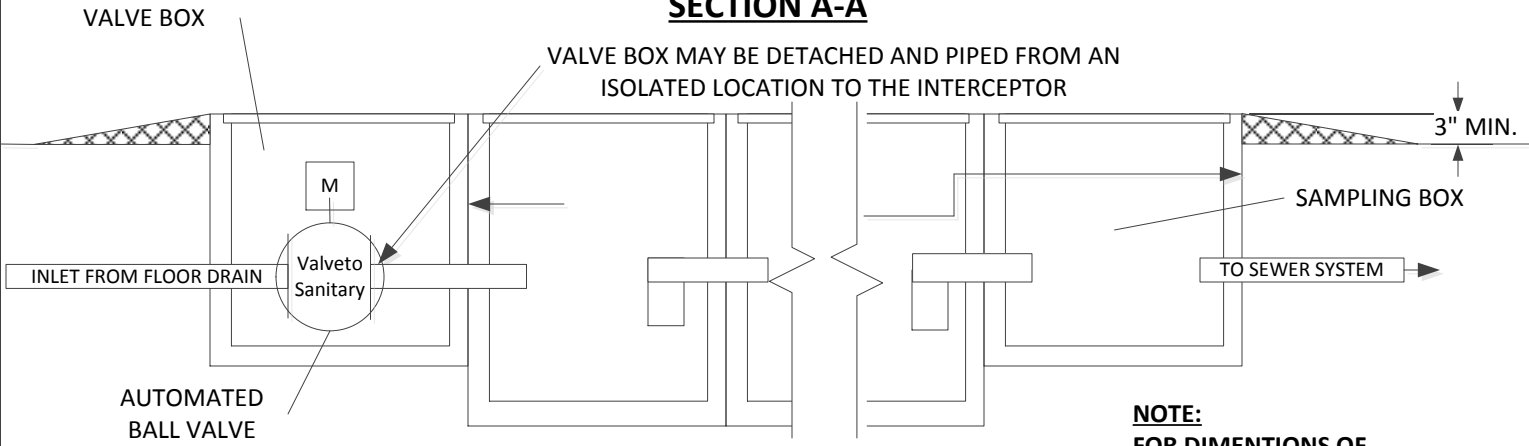

NOTE:
FOR DIMENTIONS OF INTERCEPTOR AND SAMPLING BOX SEE STANDARD PLAN 2041.

WWW.CIAGENT-STORMWATER.COM

REV 0	AUTOMATIC STORMWATER DIVERSION SYSTEM	2/15/2014	STANDARD PLAN 3-WAY AUTOMATED VALVE SHEET 1 of 2
TITLE			
APPROVED			

NOTES

1. *WARNING LIGHT TO BE LOCATED IN THE OPERATIONAL ROOM OR OTHER SUITABLE LOCATION. POST A SIGN TO READ "NOTIFY OPERATOR WHEN RED WARNING LAMP IS ON.*
2. *THE RAIN SWITCH WILL PROVIDE A SIGNAL TO THE AUTOMATED VALVE TO SHUT OFF ACCESS TO THE SANITARY SEWER AND OPEN ACCESS TO THE STORM DRAIN AFTER 0.1" OF RAINFALL OVER ANY CONTINUOUS 120 MINUTE PERIOD.*
3. *VALVE WILL BE FULL PORT DESIGN TO PREVENT DEBRIS FROM BACKING UP FLOW.*
4. *ALL WATER MUST ENTER THRU THE INLET PIPE ONLY. ALL SURFACE WATER MUST DRAIN AWAY FROM THE INTERCEPTOR AND VALVE BOX TO EXCLUDE RAINWATER FROM THE PUBLIC SEWER.*
5. *VALVE BOX AND INTERCEPTOR MAY BE MAY BE MONOLITHIC OR CAST SEPERATLY AND JOINED TOGETHER WITH EPOXY RESIGN.*
6. *THE RAIN COLLECTOR MUST BE LOCATED FREE FROM OBSTRUCTION AND VERTICALLY ABOVE THE RAINSWITCH MUST ALWAYS HAVE A CLEAR VIEW OF THE SKY.*
7. *AUTOMATED VALVE WILL BE RATED FOR SUBMERSION.*
8. *VALVES WILL BE DESIGNED AND CONFIGURED AS (2) 2-WAY FULL PORT BALL VALVES WITH AN INLET FROM THE UNCOVERED SLAB AND OUTLET NORMALLT TO THE SANITARY HOWEVER CAN DIVERT TO THE STORM DRAIN .*
9. *THE VALVES WILL ALSO HAVE A PROVISION TO AUTOMATICALLY FULLY CLOSE AND THEN FULLY OPEN THE VALVE AT LEAST EVERY 30 DAY SHOULD IT NOT OTHERWISE BE EXERCISED BY STORM EVENT OR OTHERWISE EXERCISING TO KEEP THE VALVE AND ACTUATOR IN GOOD RUNNUNG ORDER.*
10. *THE CONTROLLER WILL INDICATE BY CONTINUALLY BLINKING LIGHTS SHOULD THE AUTOMATED VALVE EVER BECOME DISABLED AND NOT REACH ITS INTENDED POSITION.*
11. *THE AUTOMATED VALVE MUST HAVE A MANUAL OVERRIDE INCASE OF LOSS OF POWER*
12. *PLC SHALL AUTOMATICALLY RESTART UPON RESTORATION OF ELECTRICITY AFTER A POWER OUTAGE.*

WWW.ATTITUDESYSTEMS.COM

(714) 880-9992 Phone